



ARO



Since 1908

MULINO AD ANELLO ROTANTE

Particolarmente indicato per la macinazione fine di materiali anche molto abrasivi, con minime usure.

Macchine chiuse e silenziose, adatte sia per cava che per industria.

ROTARY ROLLER MILL

Particularly fit for the fine grinding of even very abrasive materials, with low wear.

Closed and noiseless machines suitable both for quarry and for industry.

BROYER À ANNEAU ROULANT

Particulièrement étudiés pour le broyage fin de matériaux aussi très abrasifs, avec minimum d'usure.

Appareils fermés et silencieux aptes soit pour carrière que pour industrie.

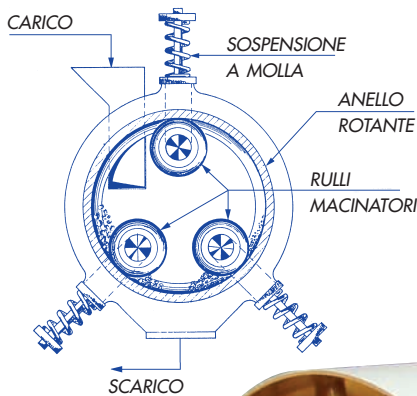

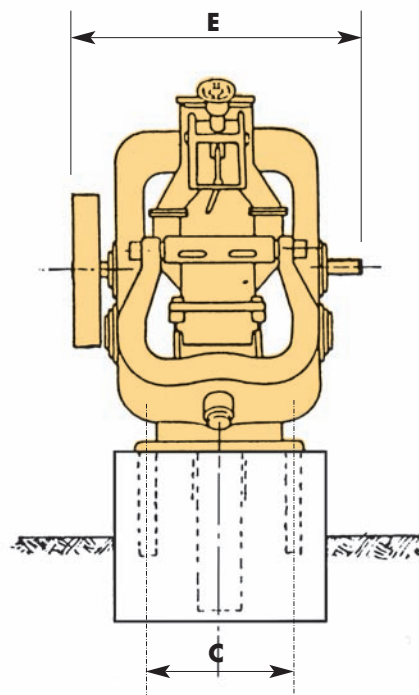
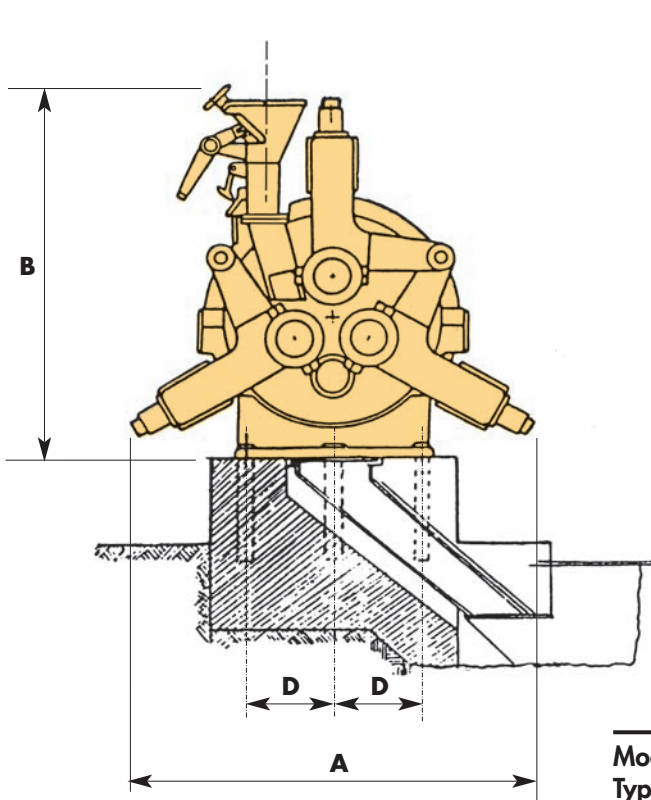

Modello Type/Modèle	A	B	C	D	E
MINOR [mm]	1.500	1.750	480	330	1.300
MEDIUM [mm]	2.300	2.200	810	500	1.840
MAJOR [mm]	2.950	2.700	1.180	650	2.415

Modello	Dimensione Bocca	Pezzatura Max. Alimentazione	Produzione	Potenza installata	Giri max. macchina	Diametro anello	Peso macchina
Type	Upper mouth opening	Max. feed size suggested	Production	Installed power	Machine r.p.m. Max.	Ring diameter	Machine weight
Modèle	Ouverture	Granulometrie Max. conseillée	Production	Puissance installée	Vitesse de rotation Max.	Diametre anneau	Poids machine
	[mm]	[mm]	[T/h]	[kW]	[rpm]	[mm]	[kg]
MINOR	400 x 400	15	4 ÷ 9	22	270 ÷ 300	660	2.500
MEDIUM	400 x 400	25	6 ÷ 18	45	175 ÷ 210	860	6.000
MAJOR	370 x 525	40	15 ÷ 25	90	140 ÷ 170	1.100	12.000

Le caratteristiche e le dimensioni sono indicative e la MEM si riserva di apportare modifiche e miglioramenti per ragioni commerciali e tecniche in qualsiasi momento e senza preavviso.

Features and dimensions are indicatives and MEM can make changes and improvements for commercial and technical reasons at any moment and without notice.

Les caractéristiques et dimensions sont indicatives et la MEM se réserve d'apporter modifications et améliorations pour raisons commerciales et techniques en quelconque moment et sans préavis.

MEM PROGETTA E COSTRUISCE LA PIÙ VASTA GAMMA DI MACCHINE PER LA FRANTUMAZIONE DEGLI INERTI, REALIZZATE IN ITALIA



MEM Società Generale Macchine Edili S.p.A.

Direzione e Stabilimento

Via R. Sanzio n° 18/20 - 20090 Segrate (Milano) Italia

Fax: 00 39 02 2136435 - E-mail: info@memitaly.com

Tel.: 00 39 02 2189 521 - www.memitaly.com

GESTIONE DI:

IMPIANTI DI PRODUZIONE,
IMPIANTI DI TRATTAMENTO
INERTI E RECYCLING

PROGETTAZIONE
REALIZZAZIONE
INSTALLAZIONE
ASSISTENZA - RICAMBI